

Is This Machine Safely Guarded?



What's wrong with this picture?



The good news is that the mechanical power press in this picture has a frontal machine guard to prevent workers from reaching into the point of operation, i.e., the place on the machine where the material is placed so it can be cut, stamped, sheared, etc.

The bad news is that the guard isn't narrow enough to keep a worker from reaching in.

The Moral: The OSHA Mechanical Power Presses standard (Section 1910.217(c)(2)(i)(a)) requires use of point of operation machine guards that "prevent entry of hands or fingers into the point of operation by reaching through, over, under or around the guard."

The machine guard in this photo clearly fails the test. And it should come as no surprise that this photo was taken by an inspector after an actual incident in which a press operator lost his hand after reaching into the poorly guarded machine.

WHAT'S AT STAKE

How Power Press Injuries Happen

Power presses are machines that shear, punch, stamp, form, or assemble metal or other material by means of tools or dies attached to slides.

Of course, what works on metal works equally well on human flesh. That's why power presses cause so many workplace amputations and crushing injuries each year. 4 ways you can get mutilated by a power press:

1. You get caught by the tool and die
2. You get trapped by other moving parts of the machine
3. You get hit by a fast moving metal projectile launched by the machine after the tool breaks down
4. Your limbs, clothes, hair, or jewelry get entangled in the rotating parts of the machine

HOW POWER PRESS INJURIES ARE PREVENTED

4 Most Common Machine Guards

The principal method of preventing power press and other machine injuries is to use machine guards, or physical barriers that block workers' access to the danger areas. There are 4 basic kinds of machine guard:

Guards are physical barriers that block workers' access to the danger area. There are 4 basic kinds of guards:

1. Fixed guards that are a permanent part of the machine



(**Note:** The machine guard in our "Spot the OSHA Violation" quiz above is also a fixed guard; but its openings are too wide to keep a worker from reaching into the guard and making contact with the point of operation.)

2. Adjustable guards that allow for flexibility in accommodating different sizes of stock fed into the machine

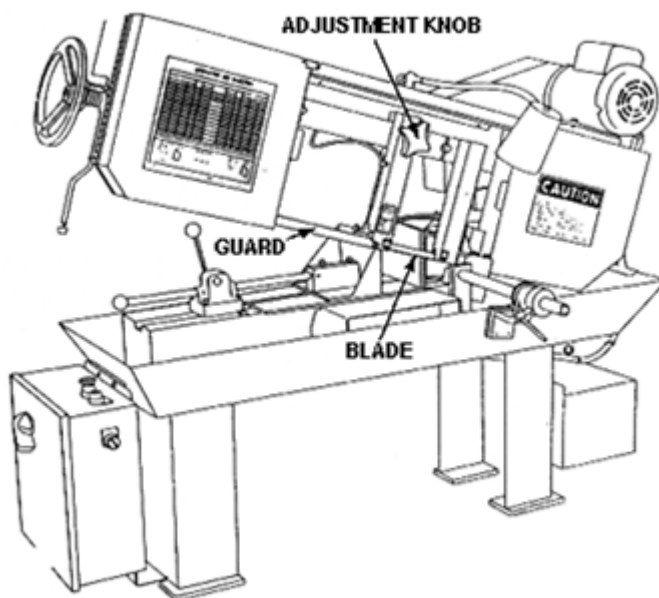

3. Interlocked guards that automatically shut off or stop the machine when a tripping mechanism is activated and keeping it stopped until the guard is put back in place



4. Self-adjusting guards in which the size of the opening in the barrier adjusts to accommodate the stock, e.g., enlarges to allow larger stock to enter



DON'T LET THIS HAPPEN TO YOU!

8 Power Press Safety Do's & Don'ts

1. **DON'T** wear loose clothing or dangling jewelry when operating a power press
2. **DO** wear a hair net or baseball cap to confine long hair when operating a press
3. **DON'T** try to oil, clean, adjust or repair a press while it's running (unless specifically authorized to do so, e.g., for troubleshooting)
4. **DO** wear safety glasses with side shields to protect your eyes from flying debris
5. **DON'T** operate, touch or mess with any machines you're not trained and operated to use
6. **DO** immediately notify your supervisor of any defects in the machinery, missing guards or other safety hazards you notice
7. **DON'T** lean or rest against a press, especially when it's operating
8. **DO** keep your hands and other body parts a safe distance away from moving machine parts, work pieces and cutters